



LMS Worldwide, Inc.
1333A North Ave. Suite 716
New Rochelle, NY 10804
Phone: 888-822-8275
Fax: 914-560-2297

Model **BCIM1000**

1000 lbs Commercial Ice Machine

FEATURES & BENEFITS

Up to 1000 lbs ice production per day

Clear, hard, cube-shaped ice

304 Stainless steel body

Air cooled condenser

Electronic controls

Uses CFC- free R404A refrigerant

NSF approved, UL listed for commercial use

Shown
with
Optional
430 lbs bin





LMS Worldwide, Inc.
 1333A North Ave. Suite 716
 New Rochelle, NY 10804
 Phone: 888-822-8275
 Fax: 914-560-2297

Model BCIM1000

1000 lbs Commercial Ice Machine

MODEL NUMBER	BCIM1000
Electrical Power	230VAC ~ 60Hz 1Ph
Power consumption	5.4 kWh/100 lbs ice
Ice-making/-harvest rated current	9.2A / 11.3A
Inlet water pipe	3/8"
Unit size (WxDxH)	30" x 24" x 26 5/8"
Unit weight	194 lbs
Packed size (WxDxH)	32 1/4" x 26 1/8" x 33 7/8"
Packed weight	208 lbs
Refrigerant	R404A
Ice production	1002 * / 795 lbs/day**
Ice cube shape	Cube
Ice cube size, in.	7/8" x 1" x 3/4"
UPC number	857244002112
20' container	69 units
40' container	108 units
40' HQ container	108 units

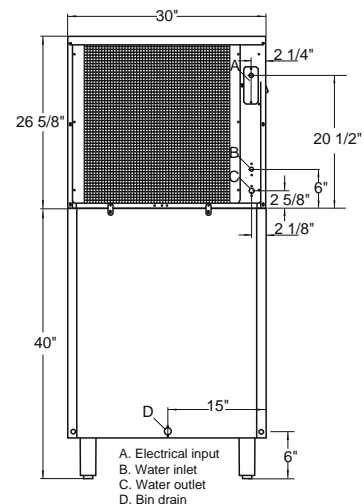
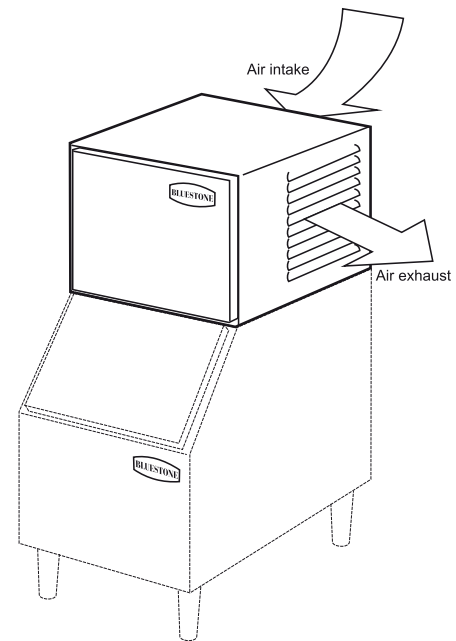

*70° F air & 50° F water / **90° F air & 70° F water. Actual quantity of ice produced per day will vary with room and water conditions. Specifications and design subject to change without notice.