



LMS Worldwide, Inc.
1333A North Ave. Suite 716
New Rochelle, NY 10804
Phone: 888-822-8275
Fax: 914-560-2297

Model **BCIM645**

645 lbs Commercial Ice Machine

FEATURES & BENEFITS

Up to 645 lbs ice production per day

Clear, hard, cube-shaped ice

304 Stainless steel body

Air cooled condenser

Stackable for increased production

Electronic controls

Uses CFC- free R404A refrigerant

NSF approved, UL listed for commercial use

Shown
with
Optional
430 lbs bin





LMS Worldwide, Inc.
 1333A North Ave. Suite 716
 New Rochelle, NY 10804
 Phone: 888-822-8275
 Fax: 914-560-2297

Model BCIM645

645 lbs Commercial Ice Machine

MODEL NUMBER	BCIM645
Electrical Power	230VAC ~ 60Hz 1Ph
Power consumption	6.8 kWh/100 lbs ice
Ice-making/-harvest rated current	7.6A / 9.85A
Inlet water pipe	3/8"
Unit size (WxDxH)	30" x 24" x 20 7/8"
Unit weight	155 lbs
Packed size (WxDxH)	32 1/4"x 26 1/8" x 28"
Packed weight	165 lbs
Refrigerant	R404A
Ice production	645 * / 511 lbs / day**
Ice cube shape	Cube
Ice cube size	3/4" x 1" x 3/4"
UPC number	857244002105
20' container	75 units
40' container	150 units
40' HQ container	150 units

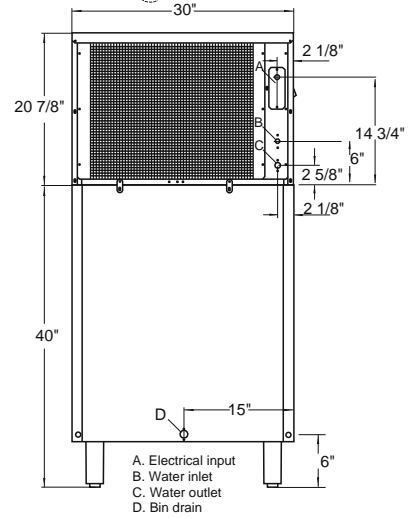
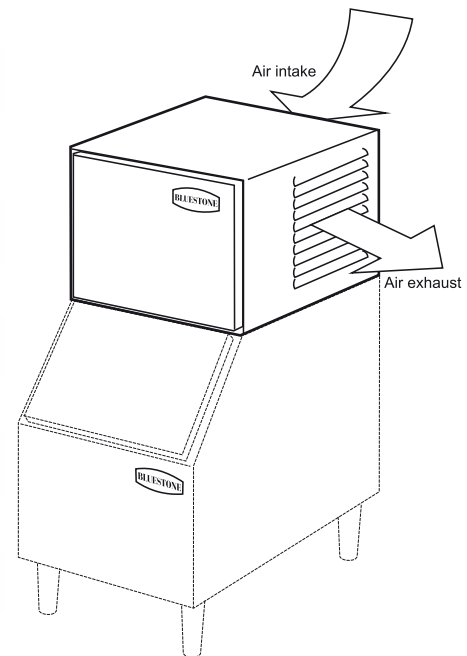

*70° F air & 50° F water / **90° F air & 70° F water. Actual quantity of ice produced per day will vary with room and water conditions. Specifications and design subject to change without notice.